

# Ultravation®

Professional Indoor Air Quality Products

## ULTRAMAX GOLD UMX REMOTE LAMP AIR DISINFECTION SYSTEMS w/ ODOR REDUCING TECHNOLOGY (PCO) OWNERS GUIDE



**Models: UMX-1200T/ UMX-1900T / UMX-1202T/ UMX-1902T – 120-240VAC Power Input with Remote Mount Lamps**

### Table of Contents:

Page 2 – Shipping and Packing list, Safety Precautions

Page 3-4 – General Application Guidelines and Recommended Installation

Page 5 – Installation Steps for External Remote Lamp Mounting with External Mounting of Power Supply, and Internal Remote Lamp Mounting with External Mounting of Power Supply

Page 6 – Installation Steps for Re-Fresh PCO Module

Page 7 –Maintenance, Troubleshooting, Lamp Replacement and Reset Procedure

Page 8 –UV Lamp Monitor, Power Consumption and Replacement Part Number, Warranty

**LEAVE FOR HOMEOWNER**

### Shipping and Packaging List:

- UMX Electrical Housing
- Ultra-Ion Re-fresh PCO module w/ gasket
- 6- 3/4 inch 5/16 self tapping sheet metal screws
- 6' Electrical Housing power cord
- Warning Label
- Residential Warranty Card

### UMX- 1200T, 1202T, 1900T, 1902T

- \*\*1200T and 1900T Series- 1 12" or 17" T3 Lamp
- \*\*1202T and 1902T Series- 2 12" or 17" T3 Lamp
- \*8 or 12 PCO module and T3 Lamp mounting plate mounting screws
- \*2 or 4 T3 Lamp mounting screws
- \*1 or 2 T3 Lamp mounting plate

\* Number depends on 1 or 2 T3 Lamps

\*\* T3 Lamp gasket included

### Safety Precautions:

It is recommended that this unit be installed and maintained by a trained technician:

**WARNING: UV Hazard. Always protect eyes from ultraviolet light. NEVER look at UV lamps in operation. Unplug or disconnect power before re-lamping or servicing.**

**WARNING: Severe eye damage or temporary blinding may occur.**

**WARNING: DO NOT operate outside of Air Handler. Mount lamp base to duct first.**

**WARNING: No openings in duct are allowed which would give direct line-of-sight to the UV light.**

In the event of accidental breakage or replacement of the ultraviolet lamp, please ensure that the lamp is disposed of in accordance with local and state environmental laws regarding fluorescent lamps containing mercury.

### Notice:

All wiring inside of the duct or air handling system in direct line of site of the UV lamp must be shielded with aluminum foil tape or equivalent non-combustible material. When installing this unit, select a mounting location that prevents ultraviolet light exposure to plastic flexible duct liner or other plastic components with unknown resistance to ultraviolet light. Ultraviolet light may cause color shift or structural degradation of plastic HVAC components

## General application guidelines for Ultramax Ultraviolet air purification systems

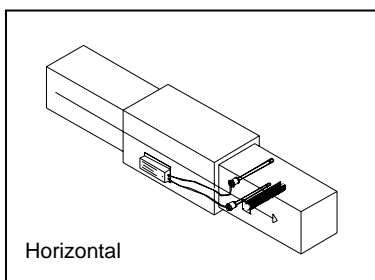
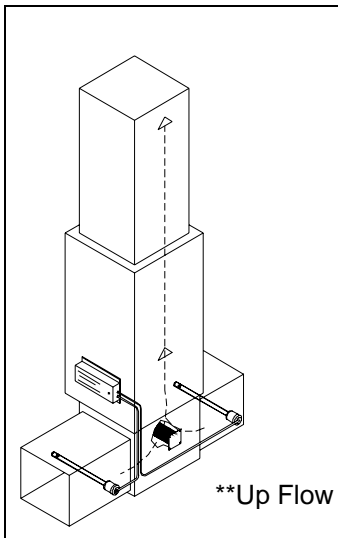
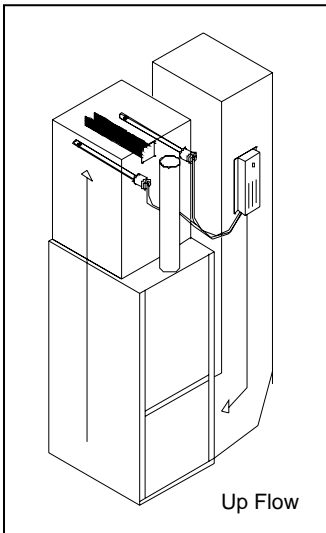

Ultravation manufactures several configurations of Ultraviolet disinfection products to meet any installation criteria. Ultravation two lamp ultraviolet systems are designed to adequately treat up to a 5 ton system or 3,500 sq ft.

Whenever possible use a two lamp configuration with the longest lamp length possible for the installation.

Ultravation suggests mounting on the exit side of the HVAC system before the ductwork branches off. This will ensure that the airborne contaminants reaching the ultraviolet purification system and the Re-Fresh Odor reduction module have been reduced to an acceptable Micron size by the HVAC systems filter.

Ultravation Ultramax products have been designed for peak performance in the cooler temperatures commonly found in the supply plenum of a typical HVAC system.

Installing an Ultraviolet system in the return may degrade the media filter and/ or collect dirt particles on the UV lamp glass gradually decreasing performance. If this is the obvious source of microbial growth then placing the Ultraviolet system in the return is the best solution. **\*\*Caution must be taken to ensure Ultraviolet light is not coming in contact with the media filter or being exposed outside the enclosed system.**

Ultravation's exclusive Re-Fresh odor reduction module performs continuous photo catalytic processing, constantly reducing or eliminating unwanted odor and bacteria resulting in clean fresh breathable air.

Ultravation Ultraviolet systems produce no ozone. There is no harmful by-products or off gasing taking place in the sterilization process or the photo catalytic process.

The surrounding illustrations show the flexibility offered with the Ultravation Ultramax product line actual installation may vary depending upon installation criteria, if you need help or have questions call our toll free help line:  
1-866-GO-UV-AIR 468-8247 ext 16  
9:00 am – 5:00 pm Est.

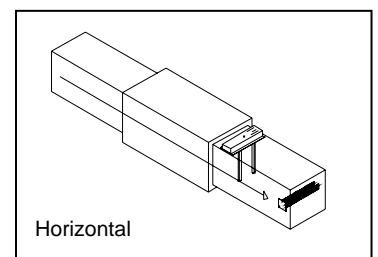
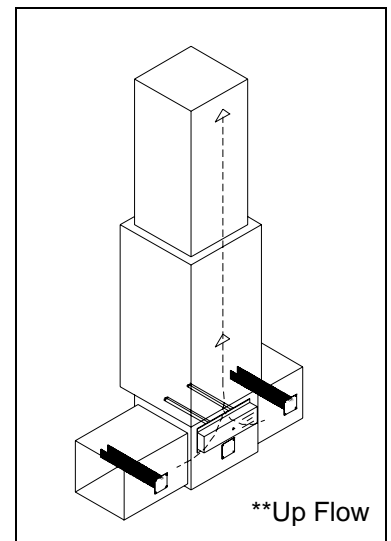
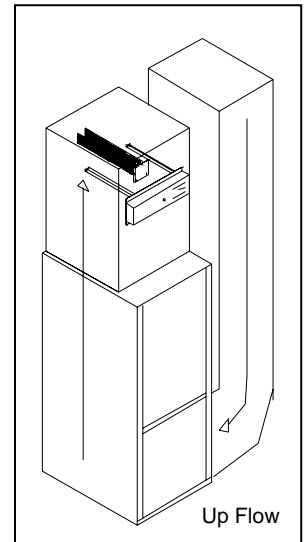

# Recommended Installation

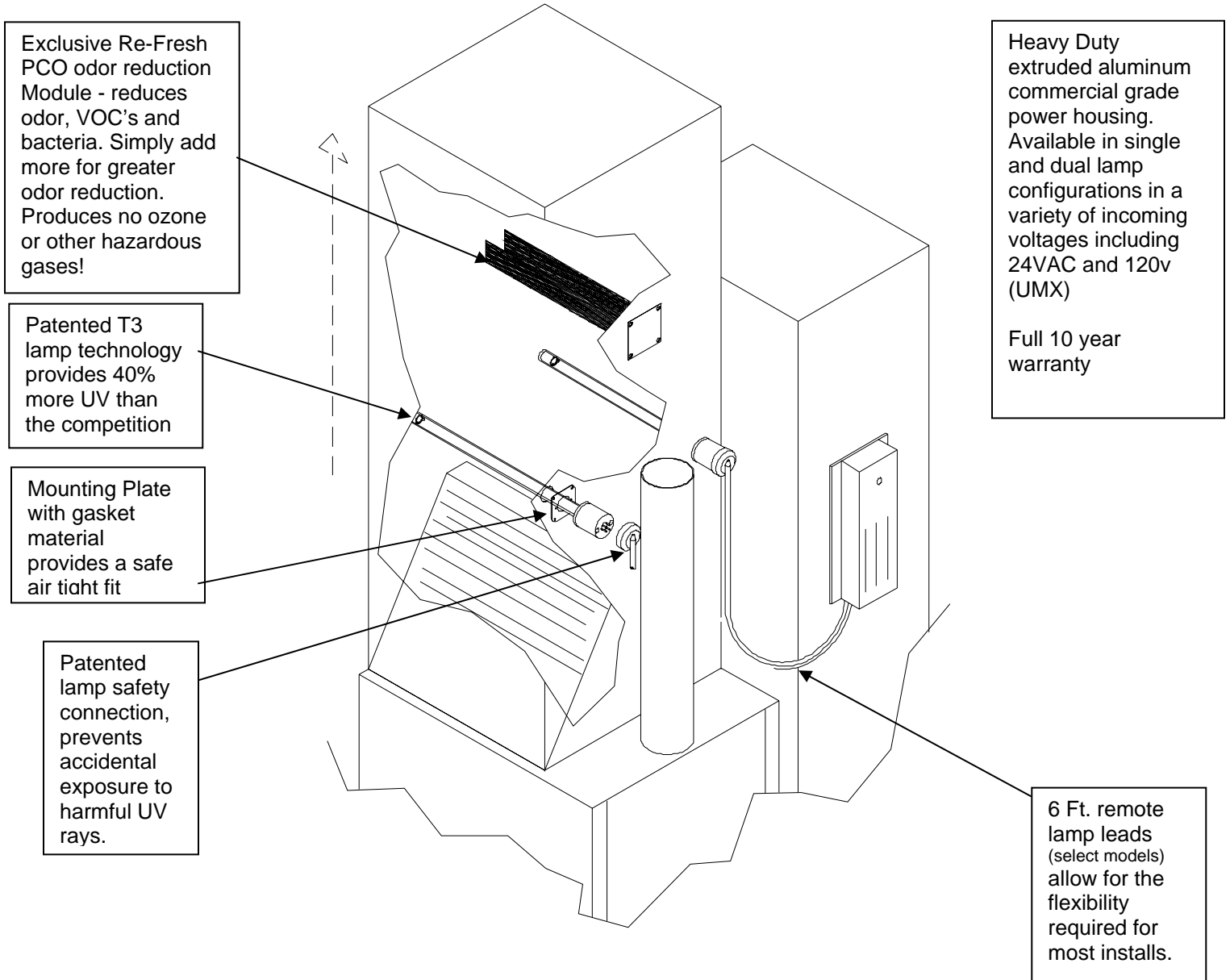

### Installation steps for remote lamp mounting, remote lamp replacement, and external mounting of power supply:

1. Determine a suitable location to install unit housing. Mounting location should be of sufficient strength as to support the unit; otherwise reinforcement of the ductwork may be necessary. Lift into place against ductwork. Fasten unit in place with four self-tapping screws (supplied).
2. Select location for UV lamp module, drill a 1" hole for each lamp. Mount mounting plate over drilled hole with screws provided. Insert UV lamp module into hole. Attach to HVAC system with 2 self-drilling screws (provided).
3. Plug the rubber lamp connector fully onto the installed UV lamp assembly. Be sure the 4 pinholes are orientated properly to the 4 mating pins of the lamp.
4. Plug in unit.

**Note: for 240 volt applications, splice off the 120 volt plug and replace with a 240 volt plug. Plug into a 240 volt receptacle.**

**Note: The T3 UV lamp assembly can be removed independently, simply by removing the 2 screws in the lamp base.**

**Note: the pins are in a rectangular patent and can only be mated in 2 positions.**

**See the illustration of the T3 lamp 4-pin connector.**

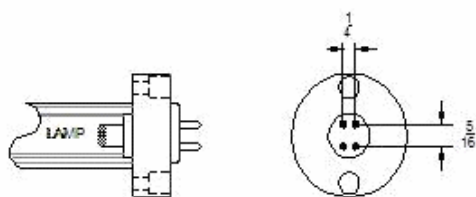

TYPICAL T3 LAMP 4 PIN CELL BASE

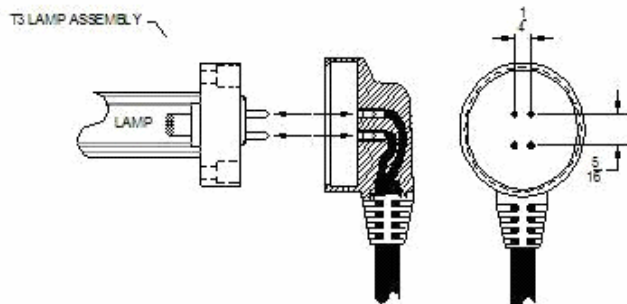

TYPICAL T3 LAMP 4 PIN CONNECTOR BASE

### Installation steps for remote lamp mounting and internal mounting of power supply:

1. Determine a suitable location to install unit housing. Mounting location should be of sufficient strength as to support the unit; otherwise reinforcement of the ductwork may be necessary. Lift into place against ductwork. Fasten unit in place with four self-tapping screws (supplied).
2. To utilize the internal mounting bracket - first install the bracket inside the air handler in a location that will position the UV lamp such that it bathes the entire surface to be treated. Next plug the lamp connector onto the lamp.
3. Plug in unit.

**Note: for 240 volt applications, splice off the 120 volt plug and replace with a 240 volt plug. Plug into a 240 volt receptacle.**

**Push the lamp connector and lamp into the bracket as shown. This will hold the lamp in place.**

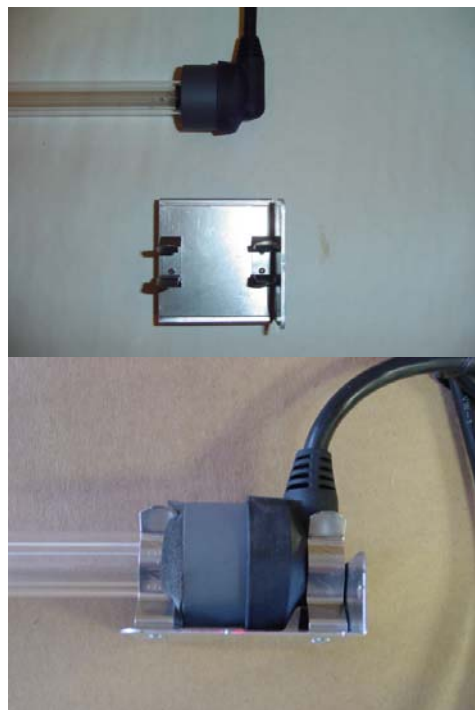

### **Installation steps for Exclusive Re-Fresh PCO odor reduction Module:**



1. Find a location adjacent to the UV lamps to mount the PCO module. To activate the PCO module it requires UV light shining on its surface. PCO module can be mounted within inches of the UV light, or if necessary the module can be within 2 ft. of direct UV light and still be activated.

2. To mount the PCO module you will need to drill one 2 1/2" diameter hole. The base plate of the module will need to be screwed to the duct or air handler with the 4 screws supplied.

3. The PCO module measures 14 3/4" inches long by 2 1/2" diameter. The surface area of the module relates directly to the amount of VOC's it can eliminate. If necessary the Module can be trimmed to a shorter length to accommodate installation in the air handler.

It is beneficial to install additional PCO modules in the area of the UV lights, thereby increasing the airborne bacteria disinfection rate and the removal of VOC's. Also the PCO modules may be installed completely internally.

## Maintenance:

Typical maintenance consists of replacement of the ultraviolet lamps.

UV lamps undergo a photochemical process during operation. This slowly reduces the amount of UV light generated to disinfect against airborne pathogens. For optimum air stream disinfection against airborne pathogens it is recommended the UV lamps be changed on an annual basis.

When installing new lamps, ensure that the lamp glass is free from any fingerprints or debris, as this may alter the path of the UV energy. Use rubbing alcohol and a dry cloth to remove any surface contaminants.

The PCO/VOC Module when used with a MERV 11 (minimum) rated filtration, no maintenance will be required for 10 years.

## Troubleshooting:

**Important information:** It is a normal characteristic of all UV lamps to blacken around the filaments of the lamp. This does not signify the lamp is defective or not emitting Ultraviolet light.

**The only time a UV lamp is defective is if it will not light. UV Lamps that illuminate will not qualify for Warranty.**

- Verify the unit has power (120-240 volt)
- When resetting the unit, depress reset button. (if the unit does not reset, wait 5 minutes to depress again)
- Power switch is in the ON position
- Lamps are securely plugged into their sockets
- The electronic circuit of a 2-lamp system only operates when both lamps are operating.
- Verify fuses are not blown. Remove both replaceable 5.0 amp MDL fuse from fuse holder and visually inspect or perform a continuity test of the fuse.
- Verify what signal if any the UV Lamp Monitor LED is emitting. (See below).
- Verify if in fact the UV lamps are on or off. **Do not look at the UV light without proper eye protection.**

**NOTE:** UMX series- If just a single UVC lamp of a 2 lamp UVC system is light, than the lamp that is not light is out of orientation.

## Lamp Replacement and Reset Procedure:

**\*See Lamp Installation for Replacement Procedure.**

**NOTE:** When replacing lamps after 1 year or 2 years of operation disconnect power to the unit first. After the lamps are in place, complete steps 1-5 to set the service indicator to 0.

**For optimum 24/7 air stream disinfection it is recommend the UV-C lamp is replaced on an annual basis.**

### Service Indicator Light:

**To set the service indicator Light: It is recommended that a certified technician perform this operation.**

1. To set or reset the annual service indicator the unit must have power to it.
2. Remove the cover from the unit, by removing the screw on the face of the unit.
3. Press down and hold the square yellow **RESET** button (hold down for 10 sec.) on circuit board (located adjacent to the LED on the circuit board), **the LED should turn GREEN** while the button is depressed.
4. Release the square yellow **RESET** button.
5. Replace the cover, and inspect operation. LED should be Green.

Please contact your local dealer or Ultravation directly for replacement lamps and batteries

There are NO user serviceable parts inside. Refer servicing to qualified service personnel.

**Note:** A flashing red every 1 seconds and a beep every 1 seconds does not necessarily mean the lamps are defective or no longer emitting UV, it is sensing the lamp(s) in the unit **are not on**. This could be caused by other factors.

In this case a service technician should be contacted.

Please contact your local dealer or HVAC contractor for replacement lamps.

There are **NO** user serviceable replacement parts other than the lamp and fuses. Refer servicing to qualified service personnel.

### UV Lamp Monitor:

LED Color	Audible Visual Alarm	Unit Status
Green	No audible	OK
Solid Red	No Audible	Reset lamp service indicator or replace lamp within 30 days
Plusing Red (Every 5 seconds)	Beep every 60 Minutes	Lamp has exceeded 1 year of operation reset or replace lamps
Flashing Red (Every 1 second)	Beep every 1 second	UV lamp(s) are not lit

### Power Consumption:

Model	Number of Lamps	Power Consumption
UMX -1200T	1-12 inch straight	19 Watts (.16 A @ 120VAC)
UMX -1900T	1-17 inch straight	29 Watts (.25 A @ 120VAC)
UMX -1202T	2-12 inch straight	38 Watts (.32 A @ 120VAC)
UMX -1902T	2-17 inch straight	58 Watts (.49 A @ 120VAC)

### Replacement Parts:

Model	Description	Replacement Part Number
UMX	12" T3 Lamp	ASIH1001
UMX	17" T3 Lamp	ASIH1003
UMX	5 Amp Fuse	EL-PP-0044
UMX	Ultra-ion Re-fresh PCO Module	94-004

### Warranty:

Ultravation warrants this product against any defects in material or workmanship for a period of 10 years after date of consumer purchase, with the exception of the Ultraviolet Lamp, which is warranted for a period of one year after date of consumer purchase.

This warranty does not include damage to the unit from accident, misuse or improper installation. If this product should become defective during the warranty period, Ultravation will elect to repair or replace the product free of charge.

Ultravation will return repaired or replaced warranted products pre-paid, provided that the product was delivered pre-paid. Ultravation shall have no responsibilities for charges incurred by the customer for installation or removal of warranted items. Liability is limited only to the replacement or repair of this product

This warranty gives you specific legal rights, and you may also have other rights, which vary from state to state. All returns must be accompanied by a return authorization number, which may be obtained by contacting Ultravation, Inc.

Ultravation, Inc. ~ P.O. Box 234 ~ 218 Jones Drive ~ Brandon, Vermont 05733  
 Phone: 802-247-0034 ~ Fax: 802-247-0033 ~ [www.ultravation.com](http://www.ultravation.com)