

Specifications
Power Consumption: .12 amps @ 230V
Lamp Length: 18" UVC Lamp
Lamp Replacement Part #: LP-PP-0033
Shield Material: Aluminum (-SS, Stainless Steel Option)

**Ultravation Low Profile
230V Electronic Power
Supply**

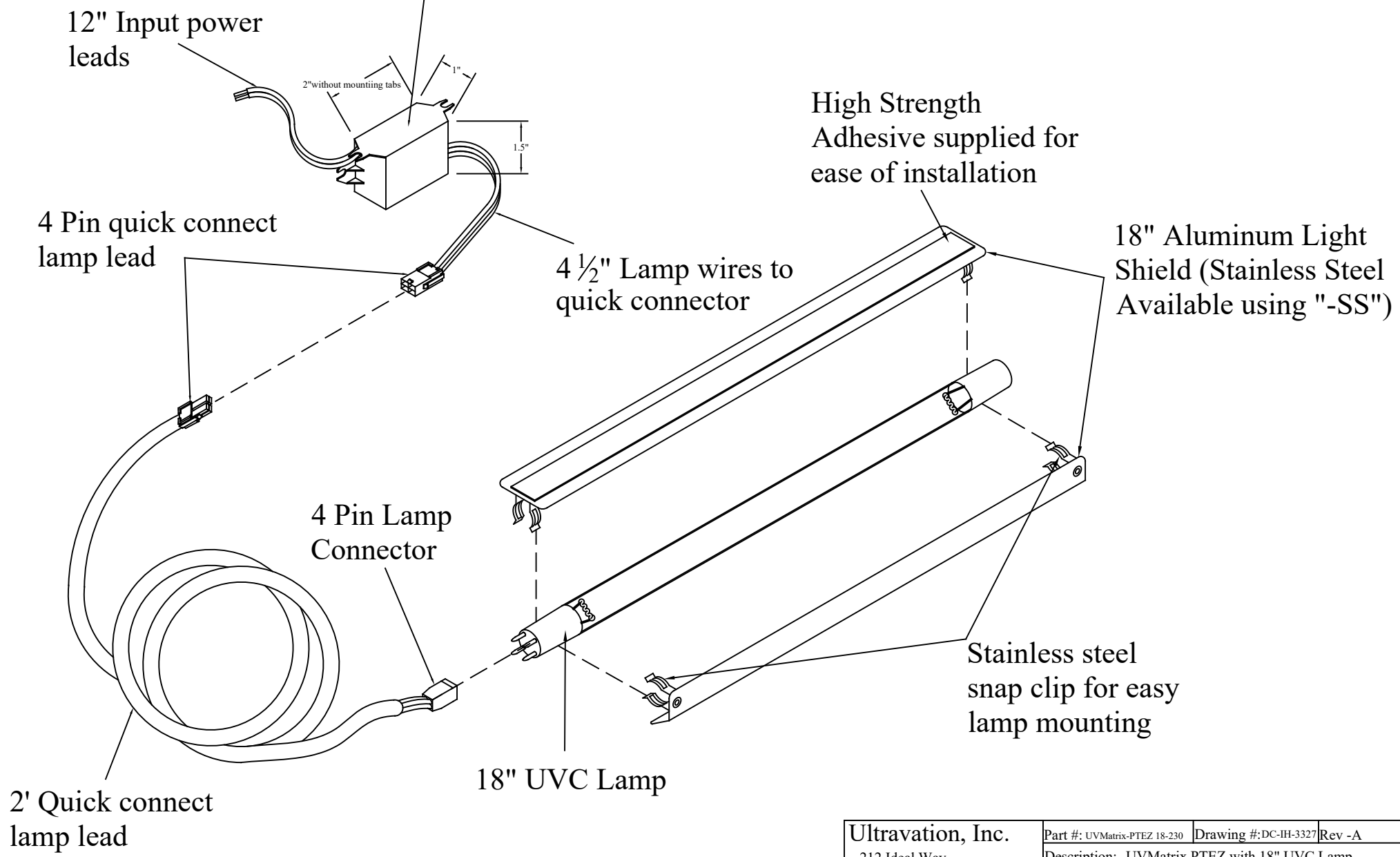

Ultravation, Inc. 212 Ideal Way Poultney, Vermont 05764 Ph: 802-287-9735 Fx: 802-287-9203 www.Ultravation.com	Part #: UVMatrix-PTEZ 18-230	Drawing #: DC-IH-3327	Rev -A
	Description: UVMatrix PTEZ with 18" UVC Lamp with high strength adhesive for ease of installation. 2' Lamp lead, 230v Operation and full length light shield.		
Date: 1/20/10	Scale:	Creator: JSM	